

X-Band Magnetron

9M31 is a fixed frequency pulsed type X-band magnetron, designed to operate in the frequency range of 9.38 to 9.44GHz with a peak output power of 50kW. It is packaged and waveguide output type and forced air cooled.

---- MAXIMUM RATINGS ----

	Min	Max	Unit
Peak anode current	3.5	16.0	A
Peak anode power input	-	230	kW
Duty cycle	-	0.001	-
Pulse duration	-	2.5	us
Rate of rise of voltage pulse	-	100	kV/us
Anode temperature	-	100	degree centigrade
V.S.W.R. at the output coupler	-	1.5:1	-

---- ELECTRICAL ----

	Min	Typical	Max	Unit
Heater voltage (Note 1)	5.7	6.3	6.9	V
Preheat time	120	-	-	S
Peak anode voltage (Note 2)	11.0	12.0	13.0	kV
Peak output power (Note 2)	40	-	-	kW
Frequency (Note2)	9.38	-	9.44	GHz

Note:

1. Measured with heater voltage of 6.3V and no anode input power, the heater current limits are 0.9A minimum, 1.1A maximum. For average pulse input powers less than 150 watts, the heater voltage must be reduced within 3 seconds after the application of h. t. according to the following schedule:

$$E_f = 6.3 \sqrt{1 - \frac{P_i}{150}} \text{ Volts}$$

(Pi=mean input power in watts.)

2. Measured at peak anode current 12.0A.

For further information on the use of the magnetron, Please contact New JRC. New JRC reserves the right to change the specification of goods without notice.

9M31

OUTLINE

Note: Dimensions are in mm

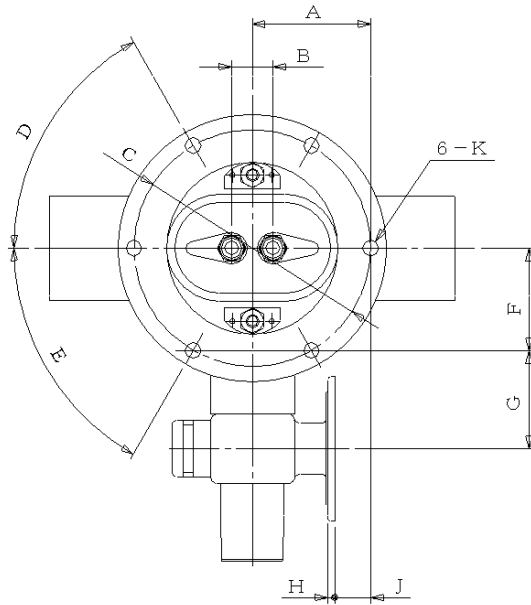

	MAX	MIN
A	37.25	35.75
B	12.95	12.45
C	φ73.15	φ72.85
D	60° 12'	59° 48'
E	60° 12'	59° 48'
F	31.61	
G	30.78	29.79
H	2.29	2.03
J	11.60	10.60
K	φ4.98	φ4.82
L	4.43	4.17
M	156.70	—
N	79.40	—
P	136.50	—
Q	83.40	81.80
R	40.18	39.18
S	φ44.63	φ44.27
T	145.90	—

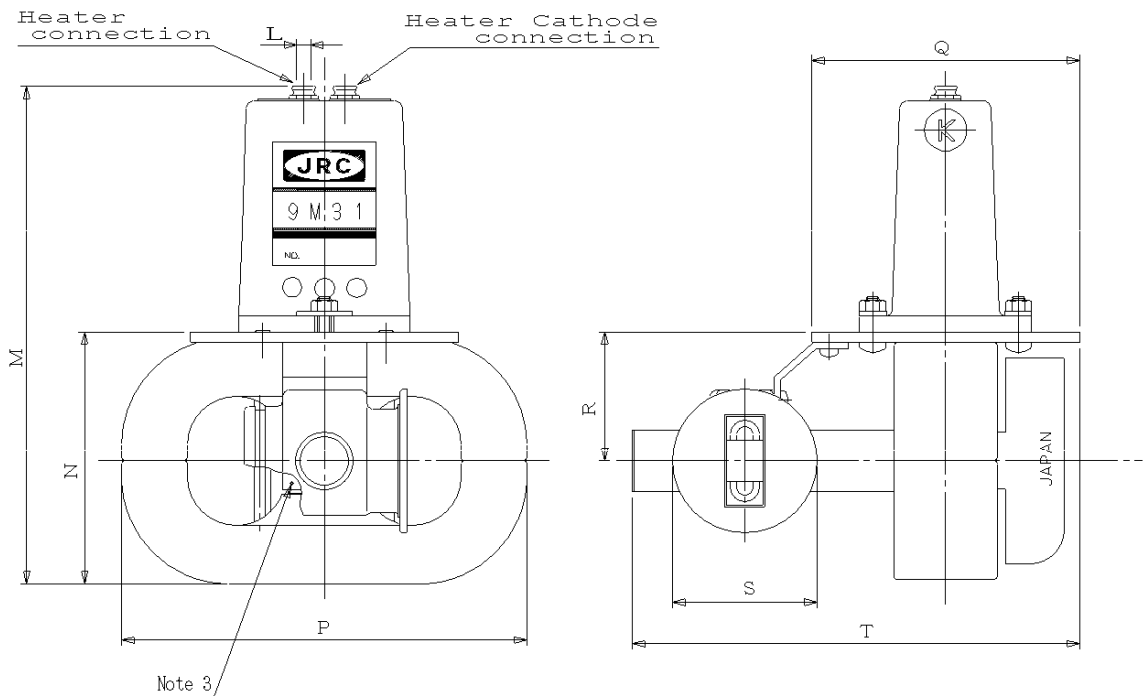

Note 3: Anode temperature measured at this point